

Networking Olancho Aid

Juticalpa, Honduras
Aug 21 – Sep 11 2008
James McBryan

Table of Contents

General Overview	3
Technical Overview	4
Broadband Internet	5
Network Topology	6
Network Management	8
Olancho Aid y Unicah	9
Santa Clara	10
Action Plan	11

General Overview

On July 31st, 2008, I received an email from my local Engineers Without Borders chapter looking for someone to volunteer with computer networking in Honduras. July 31st also happened to be the day I was starting a 1.5 week backpacking vacation. Carlos and Matthew received my email response the same day and called me just before I left the Amtrak station – this is when I confirmed I would be flying into Tegucigalpa on August 21st for a 3 week stint.

Technical Overview

The purpose of this project is to manage and improve computer and internet use throughout the Olancho Aid Network. This network is comprised of 8 locations connected via wireless bridges. Each location is in a Local Area Network (LAN) with each other and receive internet transmitted from Escuelita Nazareth.

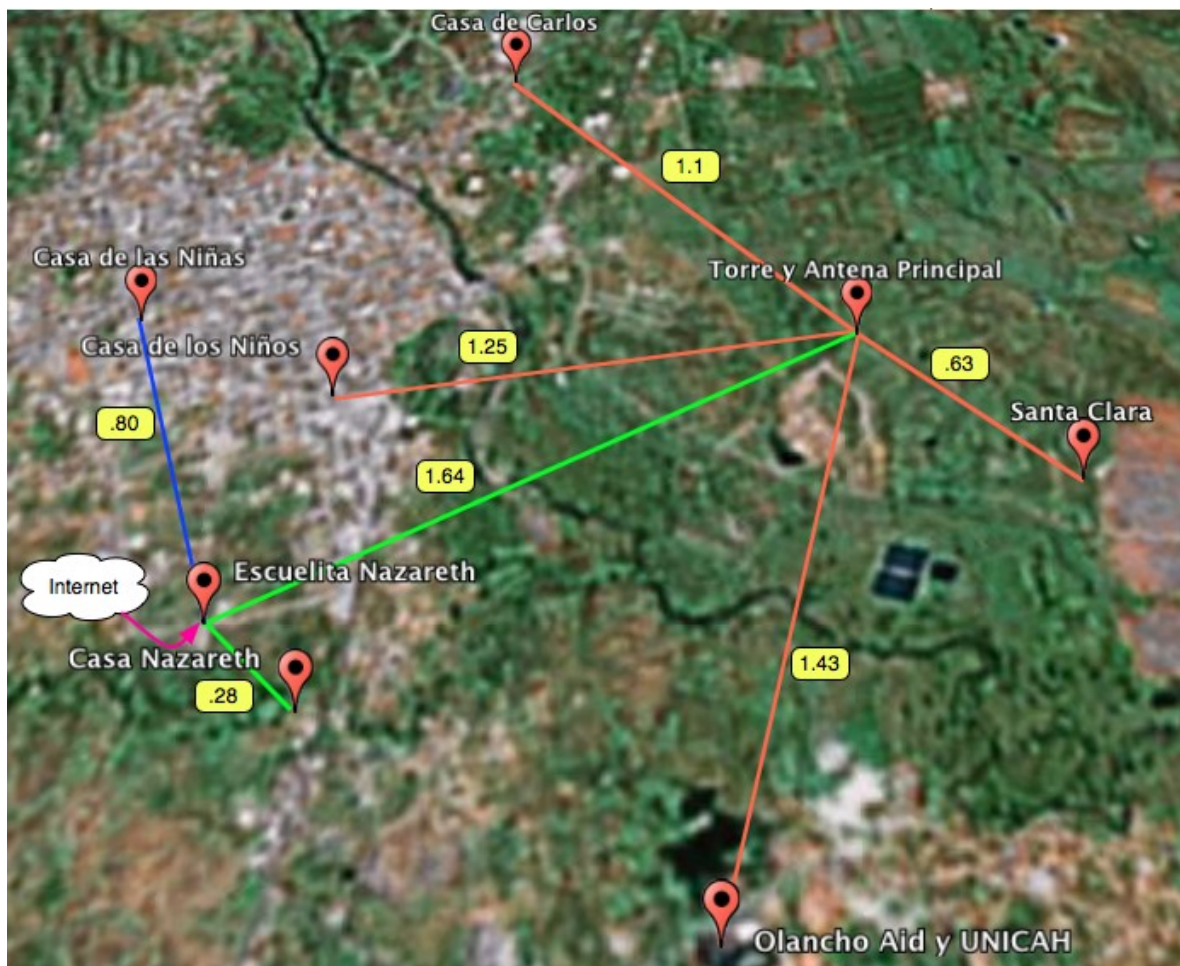

Each location has a switch or router hosting as few as 3 computers but as many as 25 computers. Escuelita Nazareth, Santa Clara, and Olancho Aid y UNIACH all have over 15 computers each since they are schools with administrative needs and computer labs. On the other hand, only 3 computers at most connect at Casa de las Ninas, Casa de los Ninos, Casa Nazareth, and Casa de Carlos.

This report will describe the current conditions and give recommendations for different parts in this network. The pieces of the report will flow naturally from biggest to smallest in regards to the photo:

- 1) Broadband Internet – how Olancho Aid gets internet
- 2) Network Topology – how all the locations are connected together
- 3) Network Management – how the LAN and internet are distributed to each location
- 4) Olancho Aid y UNICAH – how the network is setup and distributed at this location
- 5) Santa Clara – the needs of this middle school

Broadband Internet

Because Juticalpa lacks wiring to the main internet backbone, internet is sent wirelessly through cell phone company towers to Tegucialpa, to the Northern Coast, and then finally to a cable across the Carribean Sea to the United States. Olancho Aid purchases this type of internet of a speed of 256kbps upload and download for a price of \$450 US a month. According to the host, this connection can support 25 users who are solely web browsing.

Problem

The demand for the web is increasing with more powerful applications of internet videos, high-bandwidth sites like facebook or myspace, photo-blogging, and video chatting to name a few. As observed, the demand for the internet here at Olancho with just 13 computers attached to the network far surpasses 256kbps. Probably only 5 computers can comfortably share this 256kbps speed internet.

Recommendation

Obviously, the slow internet connection at Olancho Aid bottlenecks at the internet. A faster internet connection is needed for such a network with a T1 speed modem at the minimum. Olancho Aid can either:

- 1) Purchase a T1 connection from local ISPs
- 2) Purchase a T1 connection via satellite

However, even if Olancho Aid improves the internet connection, efficient connectivity cannot exist without proper distribution and management. The report discusses this in the network management section.

Network Topology

All locations in the topology are connected with point-to-point and multipoint wireless bridges. They transmit on Channel 6 through the Super Static G protocol. The point to point bridges are ASU 24005g and the multipoint bridge located at the antenna is an ASU 2410g. Through preliminary tests, the ASU 24005g has a maximum bandwidth of 2.5MB/s. According to specifications, the ASUs can emit up to 25km.

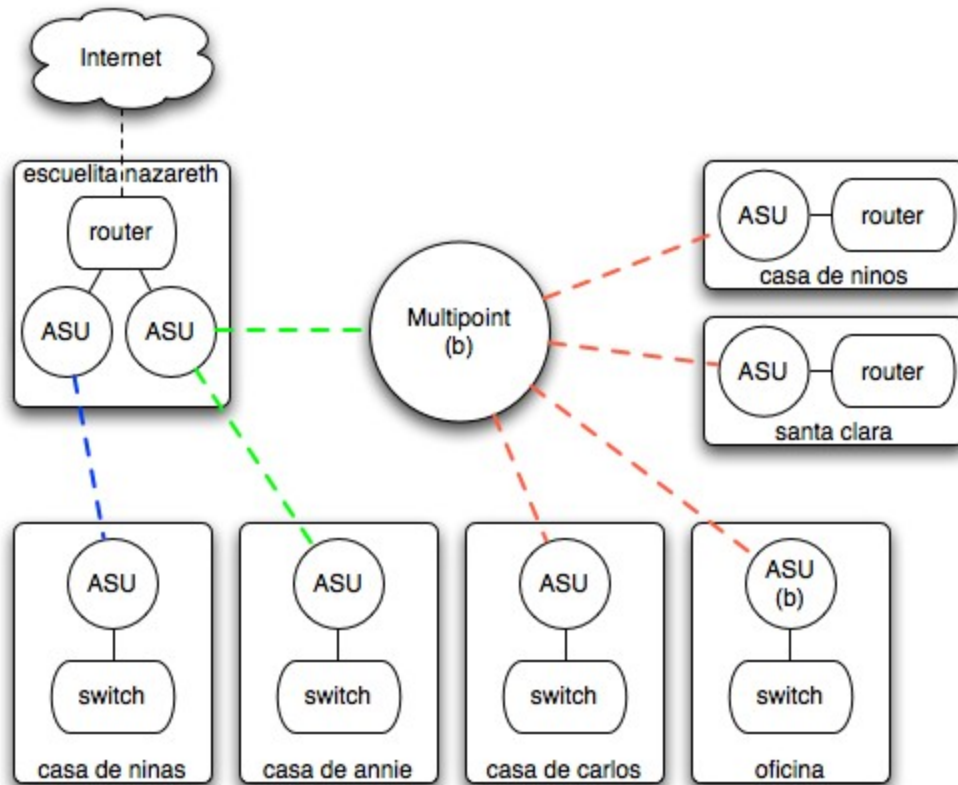

Ideally each antenna should not only have a direct line of site but also enough distance above and below the line in shape of a football field – this is called the fresnel zone:

Problem

The antennas are set up to be at their highest possible location and point to the direction of the connecting antenna. However, there is no confirmation if the Fresnel zone actually exists between two antennas. For example, the connection from Casa de Carlos to Casa de Ninos achieves at max 300kb/s. Also, the more hops a network has (internet must go from Naz to Antena to Santa Clara) the slower it can potentially be. The multipoint is currently not only an extra 'hop' but is also located near other radio towers which can cause potential interference and data packet collisions.

Also, the electricity in Juticalpa is very unstable so at any time any location can shut off. There are batteries at the Multipoint and at the ASU in the Oficina, however one can easily see that the entire network could go down if those batteries ran out.

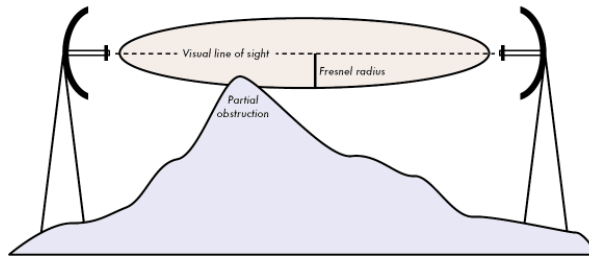
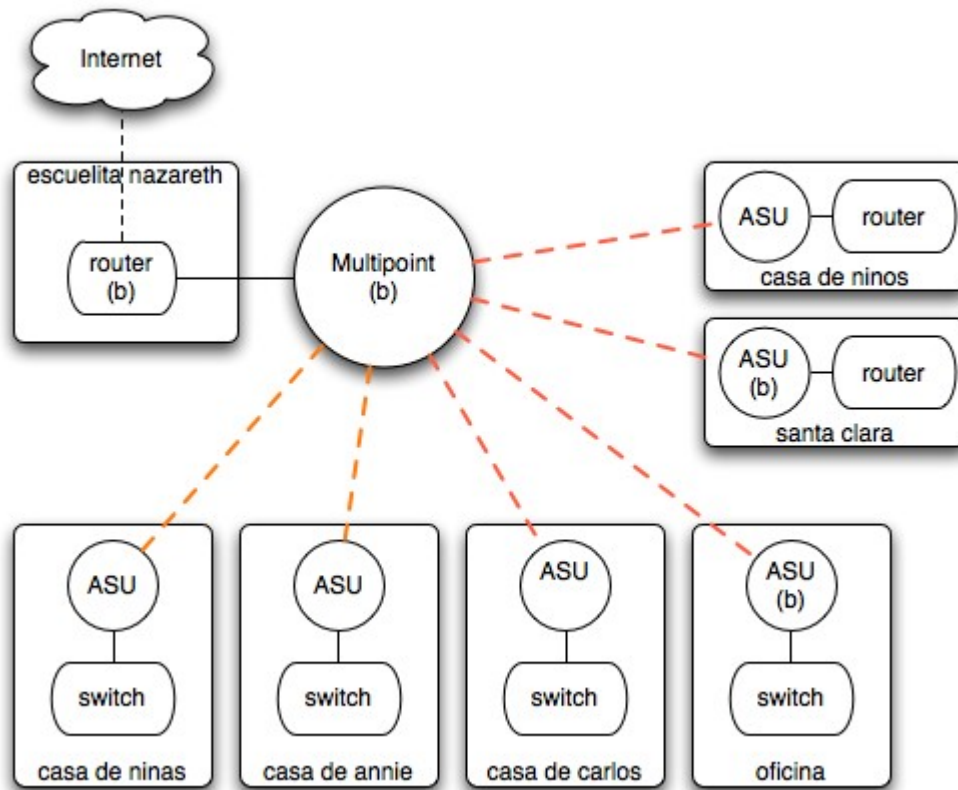

Photo of the football shaped fresnel zone

Recommendation

First it is necessary to optimize the topology as to minimize the amount of wireless hops and to make sure access to the the network is centralized.



Since Multipoint antennas are more powerful than the ASUs, it is important that the Multipoint be the channel to distribute the network. Currently, the Multipoint must go through an ASU, thus limiting its full bandwidth. But if the Multipoint were instead distributing signals to all the locations via a large antenna connected straight to the internet and backed up with a large battery, then the network would be less congested all together. Also the core points of interest – the router, the multipoint, the oficina, and santa clara – should have battery backups to keep the internet up even if the electricity cuts out.

Second, a survey should be conducted to make sure all antennas can at least have line of sight if not the fresnel zone also. It is not extremely necessary to replace any equipment, but instead they should be used in the most optimal fashion.

Network Management

Since the router distributed the internet to many locations of different types, it must enforce policies to make sure optimal bandwidth for each location. Currently a Linksys WRT54G router flashed with Tomato firmware maintains the network by acting as a DHCP server. The Tomato Router allows for Quality of Service (QoS), Port Forwarding, MAC Address & IP blocking, and Bandwidth Monitoring. These tools allow the system administrator to easily dictate which applications (i.e. Web Browsing or Chatting) should have priority on the network and to also see who is abusing the network and how they are abusing it. If necessary the network administrator can block the user.

In each location, a Linksys WRT54G router with standard firmware acts as either a switch or a router. In areas requiring easy management such as Santa Clara, a router configured with a static IP in the Tomato Router sends out its own DHCP request.

The computers themselves mostly have antivirus software (NOD) and windows firewall and have dynamic IP addresses.

Problem

The Tomato router currently performs Network Area Translation (NAT) and QoS for many computers, thus overloading it at peak times. If the bandwidth increases, traffic increases, and the Tomato router may eventually be very slow and be unable to manage the network. Though QoS is very convenient, it is all software based and thus very slow in general. Tomato is a quick solution not a sustainable solution.

If all the computers connect to the network, they must routinely update their OS and antiviri rules – obviously easily bogging down the network.

Recommendation

Installing a higher performing router to support NAT for 50-100 computers with a graphical QoS would help take care of this issue of expansion. A managed switch may also be necessary if the router does not provide any port blocking. At first thought a CISCO router comes to mind as many of its solutions are hardware based and geared toward easy management. Another option is installing a Windows or Linux Server with all the above functionality, however with the lack of an onboard system administrator any solution with the need for more than necessary management is not sustainable.

Secondly, for all the routers that are at each remote location (Santa Clara, Oficina, etc), having some kind of management would be important also – even if its just a router flashed with Tomato.

Third, users must all be informed about what they can and cannot do on the network. If they violate these rules, then they must be disconnected. The internet is always a privilege, not a right.

Lastly, most of the Olancho Aid computers use NOD32 for antivirus and Windows update– however only one needs to download the update, all the other applications should contact this own computer with the master copy. However, configuring all these computers in this fashion is painful as one has to visit every computer – if all Olancho Aid! Computers could be flashed via the network as well managed through a domain, then management would be very easy.

Olancho Aid y UNICAH

The Olancho Aid y UNICAH location provides internet for the administrative offices and for the high school (Cardenal) as they are located right next to each other. Cardenal has some administrative computers as well as a currently internetless computer laboratory of more than 20 computers. The main office of Olancho Aid connects to a domain controller with Windows Server 2003.

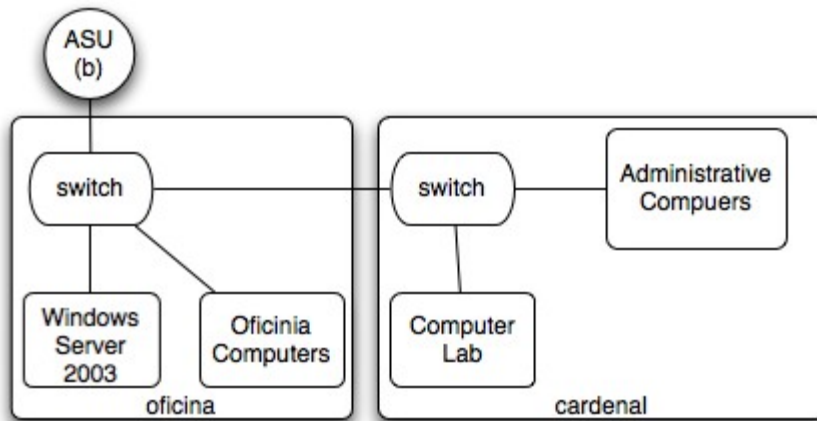

The office uses the server for domain control, DNS, and file sharing. Currently a UPS powers the server for 5 minutes after the electricity shuts off.

Problem

If Cardenal's computer lab connects to the internet, the entire Olancho Aid network will be bogged down because the students at the high school will use the internet far more so than anyone else.

The oficina has only 5 computers and they all connect to a Windows Server. The Windows Server is a Dell Poweredge but because of power issues, crashed many times during my visit over there.

Recommendation

Before Cardenal's computers connect to the internet, they need a router or their own domain controller to easily manage that many computers. This involves purchasing another router and/or another windows server. The server could also be set as a point for viral updates and windows updates for just the network or for the entire network.

As for the oficina, the server needs more power surge protection and a backup data plan. Since the material on the server is very sensitive and it is known for failure, the data must be backed up either to another server that is always on or an external drive of some sort.

Santa Clara

Santa Clara has approximately 3 administrative computers, 4 wireless teach computers, and a computer lab with 9-12 wireless computers. On another note, the librarian uses the computers to keep track of the books in a Microsoft Word table.



The ASU at Santa Clara



A computer at the computer lab

Problem

The computer lab is lacking in extra hardware, furniture, and security. Also these computers are very 'random' and do not have a standard antivirus, firewall, or OS setup.

The library cataloging system is inconvenient and inefficient, but it is better than nothing.

Recommendation

Beyond new furniture and hardware for the laboratory and high tech equipment for the librarian, having these computers connected to a server would help with the management in many ways.

Action Plan

Priority List & Budget

Below is a rudimentary action plan ordered in highest priority from the recommendations given in the previous sections. This plan is assuming that all funds are acquired and 1 nontechnical person is researching and coordinating the different activities.

- 1) Install firewall and antivirus on all computers attached to the network (\$0) – 1 week
- 2) Setup a back up server for the Peachtree data (\$0) – 1 week
- 3) Replace routers in Cardenal and Santa Clara with Tomato flashed hardware (\$120) – 1 day
- 4) Improve internet connection (\$600 / month) – 2 weeks
- 5) Centralize internet distribution with possibly new antenna placements (\$2000) – 2 months
- 6) Configure and learn CISCO managed switch and router (\$2000) – 2 weeks
- 7) Connect all Olancho computers to a domain controller or many domain controllers (\geq \$2000) – 2 weeks
- 8) Network flashing of all computers (\$0) -- 1 week
- 9) Hire someone of professional experience to manage the network -- forever

Total: (\$6120 fixed and \$600 /month) 4 Months

Future Volunteering

I plan on having my local Engineers Without Borders sponsor this project in order to

- 1) Provide 501c(3) status for hardware and software purchases
- 2) thorough research in purchases
- 3) technical recommendation and possible redesign for the Olancho Network
- 4) a return trip in 2009 to implement new recommendations